

# Model 2139



2139 Print & Apply

Printer Applicator

# 2139 Printer Applicator Specifications

The Label-Aire® Model 2139 Printer Applicator makes print and apply labeling even easier.

The Model 2139 Printer Applicator thermal transfer or direct transfer imprints and applies labels around any corner or two labels on adjacent panels utilizing a vacuumized air drum.

One-to-one print and apply allows for the immediate application of each label as it is printed. Pre-printed labels can also be applied utilizing a Model 3115 as the label dispenser. The 2139's sturdy swing arm can be configured for cartons or pallets labeling any two adjacent panels or any side requiring two labels. The heavy duty H-frame mounting stand can be bolted to the floor for added stability. The 2139 is compatible with all O.E.M. table top printers.

Put this advanced workhorse printer applicator to work for you 24/7. The Model 2139 Printer Applicator is designed to run seamlessly in your operation, saving you money in the long run.

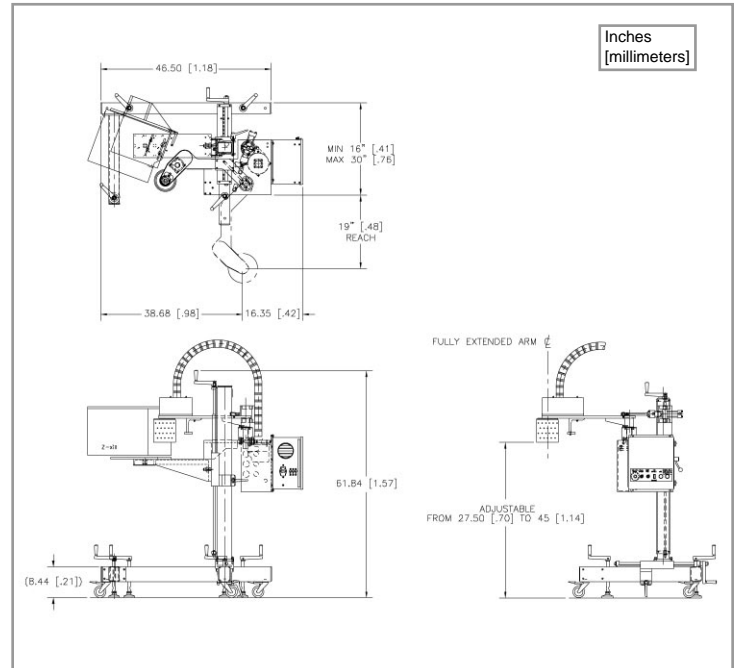

## Dimensions:

Height: 66" (1676 mm)  
Length: 62.75" (1594 mm)  
Width: 46.5" (1181 mm)

## Weight:

Approx. 500 lbs. (227 kg)

## Standard Label Dimensions:

Label Width: Up to 8.8" (224 mm)  
Label Length: Up to 24" (610 mm)  
(Printer dependent)

## Dispense Speed:

Up to 16" (406 mm) per second depending on printer and label size

## Label Placement Accuracy:

Up to +/- 1/32" (.8 mm)

## Electrical:

115 Volts AC 60 Hz 5 Amps.  
220 Volts AC 50 Hz

## Air (as needed):

4 cfm at 90 psi for most applications

## Options:

Compatible with all O.E.M. printers  
RFID configurable  
**Consult factory for additional options.**



## Headquarters

550 Burning Tree Road  
Fullerton, CA 92833 USA

o 714.441.0700  
f 714.526.0300  
e info@label-aire.com  
w www.label-aire.com

## Europe

Sjaellandsvej 27A  
DK-9500 Hobro, Denmark

o +45 9657 0063  
f +45 9657 0064  
e info@label-aire-as.com  
w www.label-aire-as.com

Distributed by:

