

*Shown with optional 3138-N Merge Printer Applicator, vision inspection system, eject station and optional 8 foot (2,438.4 mm) trunnion roller conveyor.*

**NEW**

## Trunnion Series

Labeling System

The NEW Label-Aire<sup>®</sup> Trunnion Series labeling system accurately wrap applies labels at high speeds to small diameter products at an affordable price. Trunnion labeling has never been easier!

Based on the industry-proven stainless steel cabinet based Inline Series 5100 labeling system, the Trunnion Series continues Label-Aire's longstanding tradition of advanced features, toughness, speed, and accuracy spelling lower operating costs and increased productivity for your operation. The Trunnion Series is specifically designed to handle non-stable cylindrical containers or products (i.e., top heavy or rounded bottom) including vials, ampoules, lip balm/lipstick containers, small batteries, crayons, pens, etc.

The NEW advanced yet rugged Trunnion Series labeling system is a stainless steel cabinet based PLC-controlled labeling system designed for heavy duty wrap labeling applications. The Trunnion Series can be specifically built for horizontal-, vertical-, or angled trunnion labeling. Among its standard features are a rotating control panel and a 6 foot (1,828.8 mm) trunnion roller conveyor with stainless steel side plates. An 8 foot (2,438.4 mm) trunnion roller conveyor is optional. Other standard features include Automatic Speed Following (ASF) for product surface profiling, Variable Frequency Drive (VFD), and tilt adjustments for maximum versatility. The Trunnion Series' long list of options include a choice of Label-Aire New Generation 3100/3000 Series applicators, wrap belt, stainless steel side plates, stainless steel frame, and stainless steel cabinet.

Put this proven trunnion labeling technology to work for you all day, every day. The Trunnion Series is built to meticulous quality standards and designed to work in the most hostile environments.

Have a Label-Aire Authorized Distributor contact you. Visit [www.label-aire.com](http://www.label-aire.com).



# Trunnion Series Specifications

## Dimensions:

Height: 71.5" (1,817 mm)  
 Length:\* 95.625" (2,430 mm)  
 Width:\*\* 21.875" (555 mm)

## Weight:

Approx. 1,800 lbs. (817 kg)

## Standard Label Dimensions:

Consult factory

## Label Packaging:

Consult factory

## Conveyor Speed:

Up to 1,200" (30.48 m) per minute  
 with Variable Frequency  
 Drive (VFD)

## Label Dispense Accuracy: \*\*\*

Up to +/- 1/32" (.8 mm)

## Electrical:

120 Volts AC 60 Hz 20 Amps.  
 220 Volts AC 50 Hz optional (CE)

## Air:

2 cfm at 60 psi to 90 psi required  
 with imprinter and/or eject options

## Options:

**Consult factory for additional options.**

\*Optional conveyor length; six foot conveyor (1,828.8 mm) is standard

\*\*Without label applicators

\*\*\*Model 3115 Wipe-On specifications

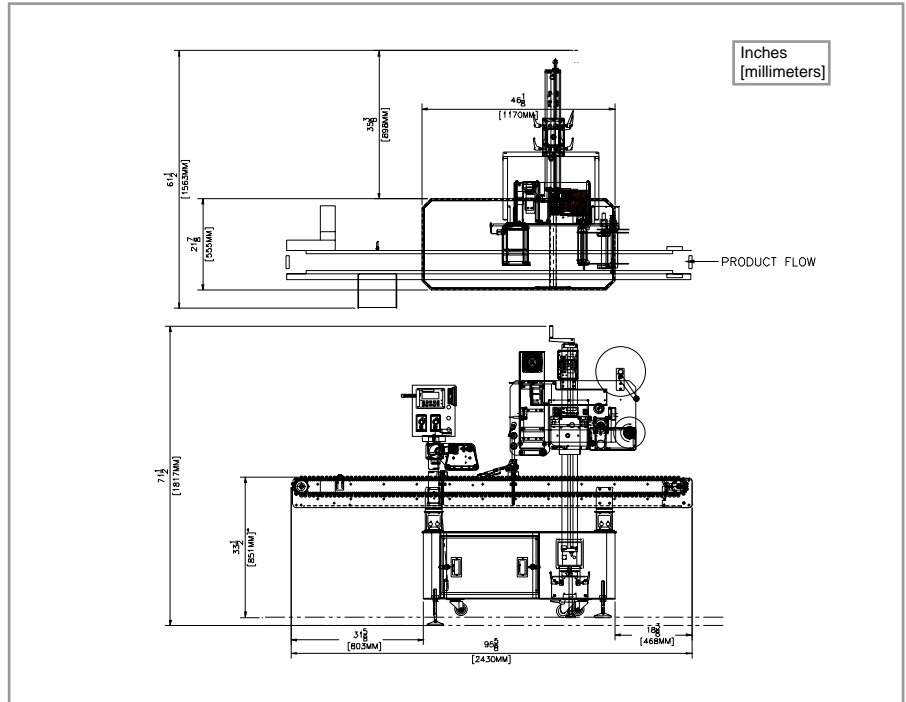

Stated dimensions are approximations. Please consult factory if dimensions are required for line integration.

<b>Main Drive:</b> Line Speed	Variable Frequency Drive (VFD) up to 1,200" (30.48 m) per minute
<b>Construction:</b> Frame Cabinet	Stainless Steel Stainless Steel
<b>Conveyor:</b> Width Length Height	Stainless Steel Side Plates Consult Factory 6' (1,828.8 mm center line-to-center line), 8' (2,438.2 mm) length optional 36" (914.4 mm) ± 2" (50.8 mm)
<b>Applicator:</b>	Label-Aire 3100/3000 Series Primary Applicators
<b>Operator Interface:</b> Control	VFD Speed Control Push Button Start/Stop
<b>Wrap Belt:</b> Drive	Consult Factory VFD



## Headquarters

550 Burning Tree Road  
 Fullerton, CA 92833 USA

o 714.449.5155  
 f 714.526.0300  
 e info@label-aire.com  
 w www.label-aire.com

## Europe

Sjællandsvej 27A  
 DK-9500 Hobro, Denmark

o +45.9657.0063  
 f +45.9657.0064  
 e info@label-aire.com  
 w www.label-aire.com

## Asia

No. 10, Lane 228, Taisi S. Road  
 Longjing Township  
 Taichung County 434, Taiwan

o +886.4.2395.5684  
 f +886.4.2395.8007  
 e info@label-aire.com  
 w www.label-aire.com

Distributed by:

